

This article was downloaded by:

On: 24 January 2011

Access details: *Access Details: Free Access*

Publisher *Taylor & Francis*

Informa Ltd Registered in England and Wales Registered Number: 1072954 Registered office: Mortimer House, 37-41 Mortimer Street, London W1T 3JH, UK



## Journal of Liquid Chromatography & Related Technologies

Publication details, including instructions for authors and subscription information:

<http://www.informaworld.com/smpp/title~content=t713597273>

### High Performance Liquid Chromatographic Determination of Ginsenosides Using Photoreduction Fluorescence Detection

Man K. Park<sup>a</sup>; Bak K. Kim<sup>a</sup>; Jeong H. Park<sup>a</sup>; Young G. Shin<sup>a</sup>; Kyung H. Cho<sup>a</sup>

<sup>a</sup> College of Pharmacy Seoul National University Seoul, South Korea

**To cite this Article** Park, Man K. , Kim, Bak K. , Park, Jeong H. , Shin, Young G. and Cho, Kyung H.(1995) 'High Performance Liquid Chromatographic Determination of Ginsenosides Using Photoreduction Fluorescence Detection', *Journal of Liquid Chromatography & Related Technologies*, 18: 10, 2077 – 2088

**To link to this Article:** DOI: 10.1080/10826079508013962

**URL:** <http://dx.doi.org/10.1080/10826079508013962>

PLEASE SCROLL DOWN FOR ARTICLE

Full terms and conditions of use: <http://www.informaworld.com/terms-and-conditions-of-access.pdf>

This article may be used for research, teaching and private study purposes. Any substantial or systematic reproduction, re-distribution, re-selling, loan or sub-licensing, systematic supply or distribution in any form to anyone is expressly forbidden.

The publisher does not give any warranty express or implied or make any representation that the contents will be complete or accurate or up to date. The accuracy of any instructions, formulae and drug doses should be independently verified with primary sources. The publisher shall not be liable for any loss, actions, claims, proceedings, demand or costs or damages whatsoever or howsoever caused arising directly or indirectly in connection with or arising out of the use of this material.

# HIGH PERFORMANCE LIQUID CHROMATOGRAPHIC DETERMINATION OF GINSENOSIDES USING PHOTOREDUCTION FLUORESCENCE DETECTION

MAN KI PARK, BAK KWANG KIM, JEONG HILL PARK,  
YOUNG GEUN SHIN, AND KYUNG HEE CHO

*College of Pharmacy  
Seoul National University  
Seoul 151-742, South Korea*

## ABSTRACT

A high performance liquid chromatographic method using photoreduction fluorescence detection was described for the analysis of ginsenosides. Ginsenosides were separated on an amino column using acetonitrile and aqueous 2-*tert*-butylanthraquinone(t-BAQ) solution. Column effluent was passed through a 45cm-PTFE capillary tube coiled around a 10W-UV lamp to reduce t-BAQ to a highly fluorescent dihydroxy anthracene derivative which was detected by a fluorescence detector. The detection limit for the ginsenoside Rg<sub>1</sub> by this method was found to be about 130ng. This method is less influenced by other UV-absorbing compounds compared to the conventional HPLC-UV detection method.

## **INTRODUCTION**

Ginseng has been widely used as a tonic and restorative agent in Oriental cultures. Ginsenosides are known to be the major constituents of ginseng. Many research papers describe analytical methods of ginsenosides. They include gravimetry, colorimetry, TLC-densitometry, radioimmunoassay, GC and HPLC methods. Among them GC and HPLC methods are commonly adapted for the quantitative analysis of ginsenosides (1-4).

Two advantages of GC are good sensitivity and resolution, however it requires a time-consuming sample preparation step involving hydrolysis and trimethylsilylation(4). The major disadvantage of current GC method is that the individual ginsenosides are not quantitated, i.e. only two broad group, panaxadiols and panaxatriols, can be analyzed. Bombardelli et. al. reported direct trimethylsilylation of intact ginsenosides and subsequent GC analysis using harsh GC condition(5).

HPLC methods afford simple sample preparation, however they lack the sensitivity of flame ionization detection(FID) as in GC. Ginseng saponin is a poor chromophore and consequently UV detection is limited to short wavelengths, typically 203 nm. However, many compounds absorb at this wavelengths and interfere with the analysis and the detection sensitivity is not good. The refractive index(RI) detector is much less sensitive.

Post-column photochemical reactions have recently been applied successfully to LC detection, since these methods have demonstrated the selectivity and sensitivity needed for modern analyses(12-15). Photochemical reactions have many advantages over normal thermal post-column reactions (6-8). Since photochemical reactions proceed via

free radical intermediates, the reaction rates are very fast (9-14). Photoreactions require photons instead of chemical reagents, which makes the reaction device more simple and minimizes band broadening. Furthermore, these methods have good selectivity because only a narrow range of analytes can undergo photoreaction (15-17).

In photoreduction detection, a photoreductive compound is usually added to the HPLC eluent. t-BAQ was used in this study, the photoreduction process is illustrated in SCHEME. t-BAQ itself is very weakly fluorescent but is converted to a highly fluorescent 2-tert-butylidihydroxyanthracene upon irradiation by UV light in the presence of proton-donating substrates.

Birks and Gandelman applied this method to the analysis of monosaccharides and cardiac glycosides (18,19). They used a 10m-knitted PTFE tubing coiled around the fluorescence black lamp and used anthraquinone-2,6-disulfonate (AQDS) or t-BAQ as the photoreactive additive. Their reported detection limits for monosaccharide and cardiac glycoside were about 80ng and 2ng respectively. In this paper, we report the application of this method to the analysis of ginseng saponins.

## **EXPERIMENTAL METHODS**

### **Materials**

2-*tert*-butylanthraquinone (FW 264.32, mp 98-100°C) was purchased from Aldrich and recrystallized from acetonitrile. HPLC grade water was prepared by using a Milli-Q system(Millipore). Acetonitrile (Merck, Germany) was of HPLC grade. Other chemicals were of analytical reagent grade. White ginseng and notoginseng was purchased from the local herbal drugs

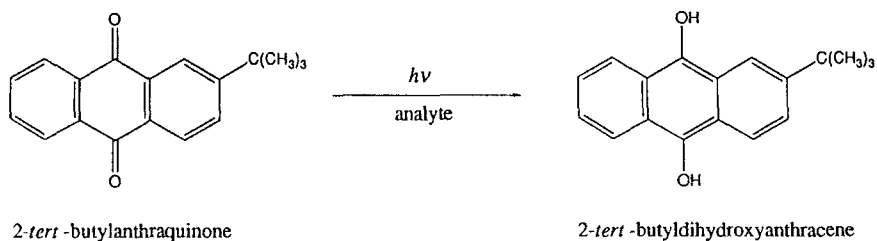

SCHEME. Mechanism of photoreduction fluorescence detection.

market in Seoul and ginseng saponin standards were obtained from Korea Ginseng and Tobacco Research Institute.

### Instruments

An SLC-100 pump (Samsung, Korea) equipped with a 50 $\mu$ l loop injector (model 7125, Rheodyne, USA), Hitachi F-1050 fluorescence detector (excitation 400nm, emission 525nm), and Hitachi L-4200 UV detector was used. Chromatographic data was processed by a Shimadzu C-R4A Chromapac integrator. For the analysis of ginseng saponins, a Lichrosorb NH<sub>2</sub> column (250mm x 4mm i.d., 10 $\mu$ m, Merck) was used and the eluent was acetonitrile/water (80/20) which contained a photoreactive additive. Figure 1 illustrates the overall photoreaction-HPLC system.

### Photochemical reactor

A 10W-UV lamp was purchased at the local electronics market (2.5cm x 32cm, cylinder type, Sam-Gong Co., Korea). The 45cm PTFE capillary tube (0.3mm i.d. x 1.5 mm o.d., Alltech associates) was coiled around the lamp and was wrapped with aluminium foil to increase the photon flux of the lamp by reflection. The reactor was purged with nitrogen to remove oxygen. The photochemical reactor is shown in Figure 2.

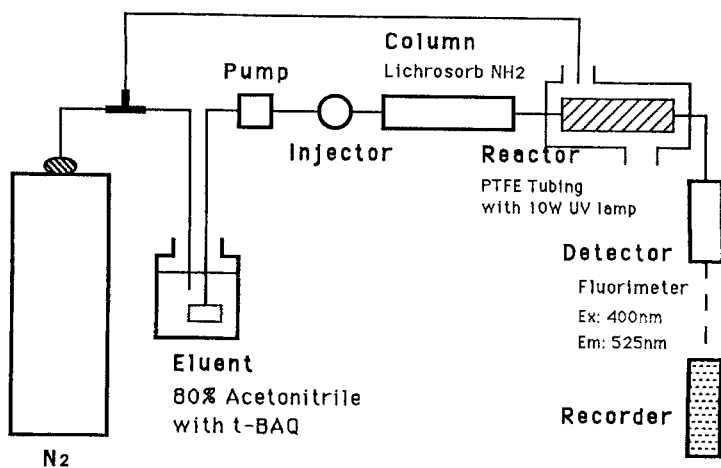

FIGURE 1. Scheme of photoreduction fluorescence detection system.

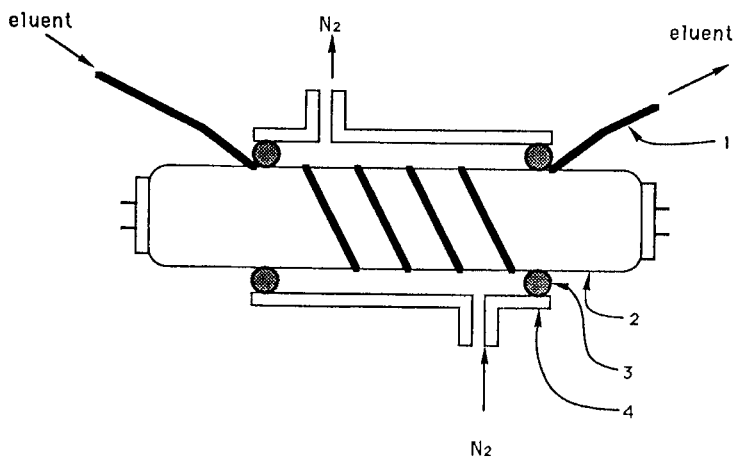

FIGURE 2. Schematic presentation of the photochemical reactor.

- 1. 45cm PTFE coil;
- 2. 10W UV lamp;
- 3. O-ring
- 4. Polyvinyl Chloride(PVC) pipe.

### Analysis of ginsenosides

White ginseng(3g) was extracted with hot methanol. The dried methanol extract was suspended in water and extracted with diethylether. The aqueous layer was extracted with water-saturated n-butanol(3 x 50 ml). Combined butanol extracts were dried under reduced pressure. The residue was dissolved in 10 ml of water, passed through a 0.45  $\mu\text{m}$  membrane filter and subjected to HPLC analysis. Notoginseng radix was treated by the same method. The peaks were identified by co-injection with authentic samples.

## **RESULTS AND DISCUSSION**

### Optimization of analytical conditions

Many factors affect the photoreaction. They include concentration of the photoreactive additive, irradiation time, photoreaction temperature, content of water in the effluent, and length of reactor coil. Among these concerns the concentration of photoreactive additive and irradiation time were the major factors which affect the S/N ratio. In order to optimize the photoreactive additive concentration, the concentration of t-BAQ was changed from  $7.5 \times 10^{-5}\text{M}$  to  $7.5 \times 10^{-4}\text{M}$  and added to the eluent of acetonitrile/water(80/20). The signals of ginsenoside Rg<sub>1</sub> or glucose was compared under these conditions. Figure 3 shows the effect of t-BAQ concentration on the signal intensity. The S/N ratio of ginsenoside Rg<sub>1</sub> increased with increased concentration of t-BAQ up to  $4.0 \times 10^{-4}\text{M}$ , however over this concentration the S/N ratio decreased. In fact, signal intensities of ginsenoside Rg<sub>1</sub> was increased even over  $4.0 \times 10^{-4}\text{M}$ , but in proportion

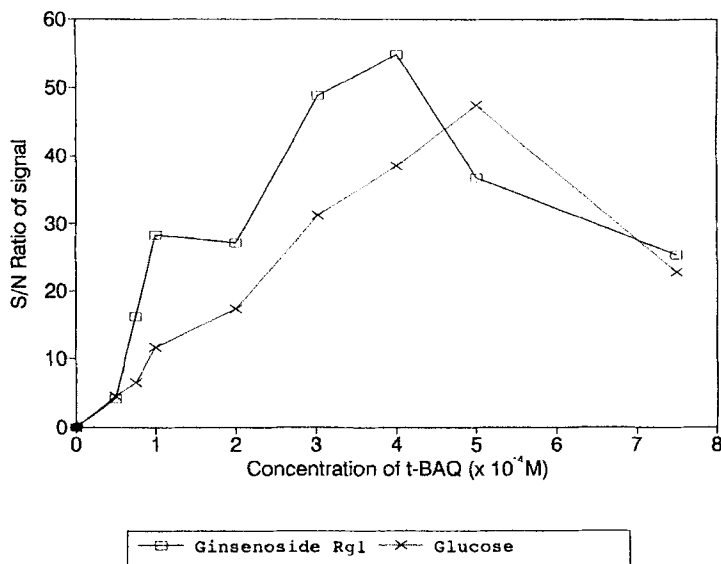

FIGURE 3. Effect of the concentration of t-BAQ on the peak response. conditions : 10W UV lamp with 45cm PTFE tubing; column : Lichrosorb  $\text{NH}_2$  column (250mm x 4mm i.d.,  $10\mu\text{m}$ ); eluent : acetonitrile/water (80/20) with various concentration of t-BAQ; flow-rate : 1ml/min; reaction time : 4sec; detection : fluorescence (excitation : 400nm, emission : 525nm).

to the concentration of t-BAQ, the fluorescence background signal intensity was also increased. Consequently, the optimal concentration of t-BAQ passing the reactor was found to be  $3.0 \times 10^{-4}$ M. Fluorescence background and noise were reduced with purified and immediately prepared eluent.

The optimal irradiation time was checked by varying the flow rate of eluent or the length of reactor coil. The irradiation time was calculated from the flow rate of the eluent and the internal volume of the capillary PTFE reaction coil. The internal volume of the reaction coil was calculated from the difference of retention time of salicylic acid with and without the reaction



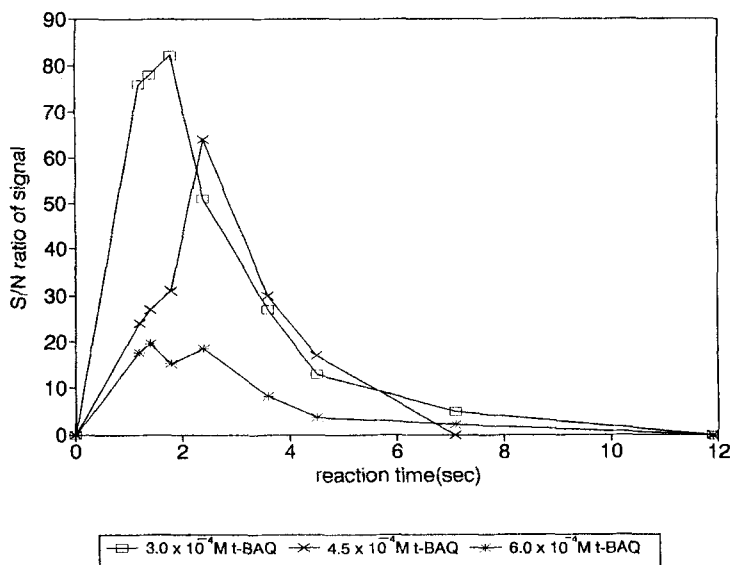

FIGURE 4. Effect of the photoreaction time to the signal-to-noise ratio of ginsenoside Rg<sub>1</sub> (conditions are same as in FIGURE 3).

coil. FIGURE 4 shows the effect of photoreaction time on the signal-to-noise ratio of ginsenoside Rg<sub>1</sub>. The highest S/N ratio was observed at 2 sec of reaction time with a  $3.0 \times 10^{-4}$  M t-BAQ solution. Both the S/N ratio and peak area were reduced with longer reaction times due to the degradation of the dihydroxyanthracene compound(18-19).

Atmospheric oxygen can penetrate the PTFE capillary resulting in noisy signals. Nitrogen purging of the reactor was very important as Birks et. al. reported (18,19). A Nitrogen purge also acts as a cooling flow of the reactor.

The percent water in the eluent also affected the signal response. An increased signal was observed using a low % water eluent. Also the amino

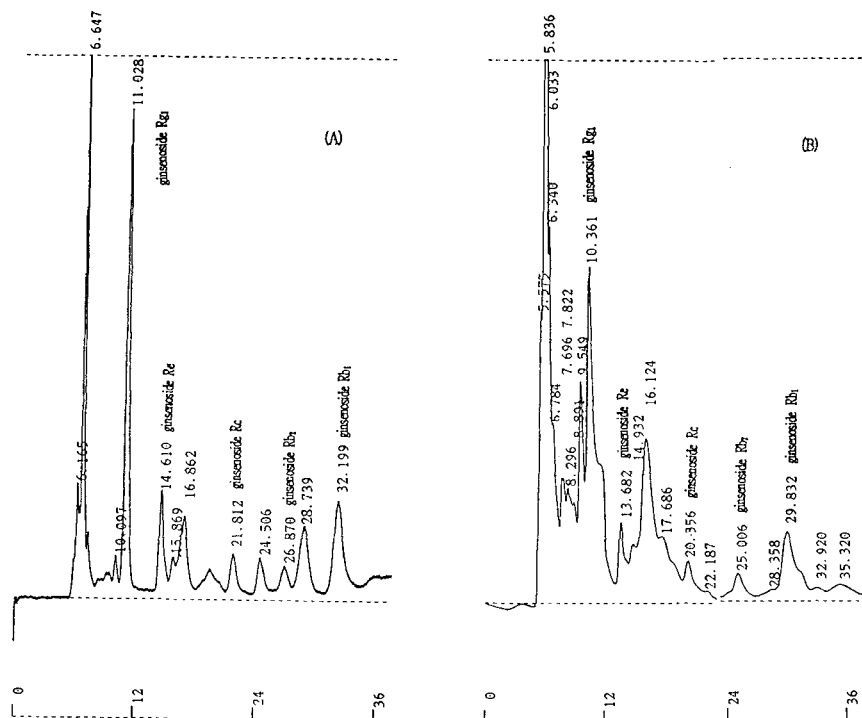

FIGURE 5. Chromatogram of white ginseng : photoreaction (A) and UV (B) detection.

conditions of (A) : 10W UV lamp with 45cm PTFE tubing; column : Lichrosorb NH<sub>2</sub> (250mm x 4mm i.d., 10μm); eluent : 80% acetonitrile with 3.03 x 10<sup>-4</sup>M t-BAQ; detection : fluorescence (excitation : 400nm, emmition : 525nm).

conditions of (B) : column : Lichrosorb NH<sub>2</sub> (250mm x 4mm i.d., 10μm); eluent : 80% acetonitrile; flow-rate : 0.7ml/min; detection : UV 203nm.

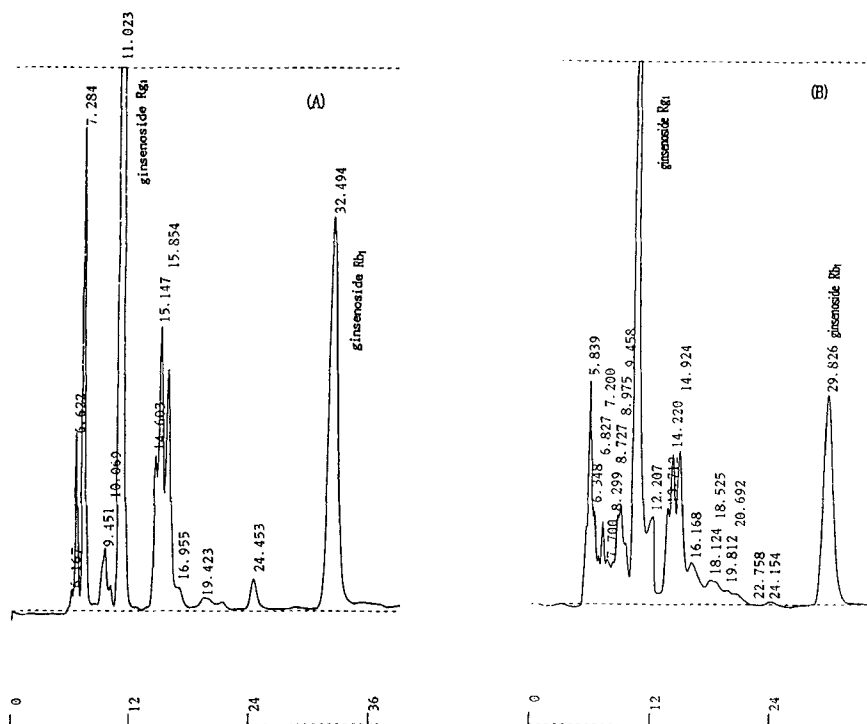

FIGURE 6. Chromatogram of Noto Ginseng root in photoreaction (A) and UV (B). Conditions are same as in FIGURE 5.

column was more efficient than an ODS column since the former can separate ginsenosides with a low-water percent eluent.

#### Calibration curve, detection limit and reproducibility

The linearity of response was examined with ginsenoside Rg<sub>1</sub>. The correlation coefficient of the calibration curve of ginsenoside Rg<sub>1</sub> and Rb<sub>1</sub> was 0.9993 in the range of 1 - 100  $\mu$ g. The detection limit(S/N=3) of ginsenoside Rg<sub>1</sub> was 125ng which was almost same as UV detection.

Detection limits of ginsenoside Rb<sub>1</sub>, Rb<sub>2</sub>, Rc, Rd, Re and Rg<sub>2</sub> were 500ng, 100ng, 250ng, 1000ng, 125ng and 1000ng, respectively. The sensitivity of the photoreaction fluorescence detection method was better than the RI detection method and similar to the UV detection method. However this method shows good selectivity for the ginsenosides.

RSD(relative standard deviation) of peak areas for the repeated injections of ginsenoside Rg<sub>1</sub> was ca. 2.3%(n=12).

### Chromatography

Figures 5 and 6 represent the chromatograms of white ginseng and notoginseng root. Compared to UV detection, the PRF method shows good selectivity for ginsenosides. UV-absorbing impurities are not detected by using PRF. Most notables are the peaks which interfere with the signals for ginsenoside Rg<sub>1</sub> and ginsenoside Re when UV detection is employed. These impurity peaks are greatly attenuated or absent when PRF is the method of detection.

### **ACKNOWLEDGEMENT**

This work was supported by S.N.U. Posco Research Fund(92-08-2081). We are grateful to Korea Ginseng and Tobacco Research Institute for the generous gift of ginsenoside standards.

### **REFERENCES**

1. F. Soldati, O. Sticher, *Planta Medica*, **38**, 348-357 (1980)
2. E. K. Park, *Yakhakhoeji*, **23**, 181-186 (1979)

3. K. J. Choi, *Saengyakhakhoeji*, 20, 175-179 (1989)
4. M. K. Park, J. H. Park, J. S. Kang, M. Y. Lee, Y. I. Park, S. J. Yu, B. H. Han, *Kor. J. Ginseng Sci.*, 17(1), 35-38(1993)
5. E. Bombardelli, A. Bonat, B. Gabetta, E. M. Martinelli, *J. Chromatogr.*, 196, 121-132(1980)
6. R. W. Frei, H. Jansen, *Anal. Chem.*, 57(14), 1529A(1985)
7. C. M. Selavka, K. Jiao, I. S. Krull, *Anal. Chem.*, 59, 2221-2224 (1989)
8. J. R. Poulsen, K. S. Birks, *Chromatographia*, 22, 231-234(1986)
9. F. Wilkinson, *J. Phys. Chem.*, 66, 2569-2574 (1962)
10. K. B. Patel, R. L. Willson, *J. Chem. Soc., Faraday Trans 1*, 69, 814 (1973)
11. L. A. Treinin, H. Linschitz, *J. Phys. Chem.*, 87, 2536-2544(1983)
12. J. N. Moore, *J. Chem. Soc., Faraday Trans 2*, 82, 745-761(1986)
13. S. A. Carlson, *Photochemistry and Photobiology*, 17, 123-131 (1973)
14. A. Harrison, *Photochemistry and Photobiology*, 33, 619-625(1981)
15. M. S. Gandelman, J. W. Birks, *J. Chromatogr.*, 242, 21-31(1982)
16. M. S. Gandelman, J. W. Birks, *Anal. Chem.*, 54, 2131-2133(1982)
17. J. R. Poulsen, J. W. Birks, *Anal. Chem.*, 61, 2267 (1989)
18. M. S. Gandelman, J. W. Birks, U. A. Th. Brinkmand, R. W. Frei, *J. Chromatogr.*, 282, 193-209 (1983)
19. M. S. Gandelman, J. W. Birks, *Anal. Chim. Acta*, 155, 159-171 (1983)

Received: December 22, 1994

Accepted: January 6, 1995